



## DIRECT LINE PLUS - HOOD TYPE DISHWASHER

### LK606



Soft top washing-up, basket 50x50cm

#### TECHNICAL DATA:

External dimensions - WxDxH (cm)	63,5x74,5x153
Basket dimensions - WxD (cm)	50x50

#### ADDITIONAL TECHNICAL DATA:

Tank capacity/hot water heater (lt)	156
Electric elem. tank /hot water heater (k)	2,18
Washing/rinsing pump (kW)	0,5-
Water consumption (lt/cycle)	2,2
Door opening (cm)	41
Softener	
Supply (N)	400V 3N 50Hz
Weight (kg)	135
Volume (m3)	0,78
Power (kW)	8,5

You will save almost EUR 800 every year because LK606 features very low consumption of water, energy and detergent. This dishwasher adjusts to your tableware thanks to its 45 cm useful opening glasses, large dishes, pizza plates, trays and utensils are easily washed. It also fits perfectly within the space you have available: the versatility of the project and the wide availability of service tables allow optimal use in any environment with in line or corner installations. Productivity is high, between 800 and 600 dishes/hour depending on the selected cycle, always running in the utmost silence and with the extraordinary effectiveness of the patented cleaning system with double flow pump and constant pressure spray arms.



A		∅ 35 mm M	A	EXIT	∅ 35 mm M
B		G 3/4" M	B	EXIT	G 3/4" F
C		Power supply			

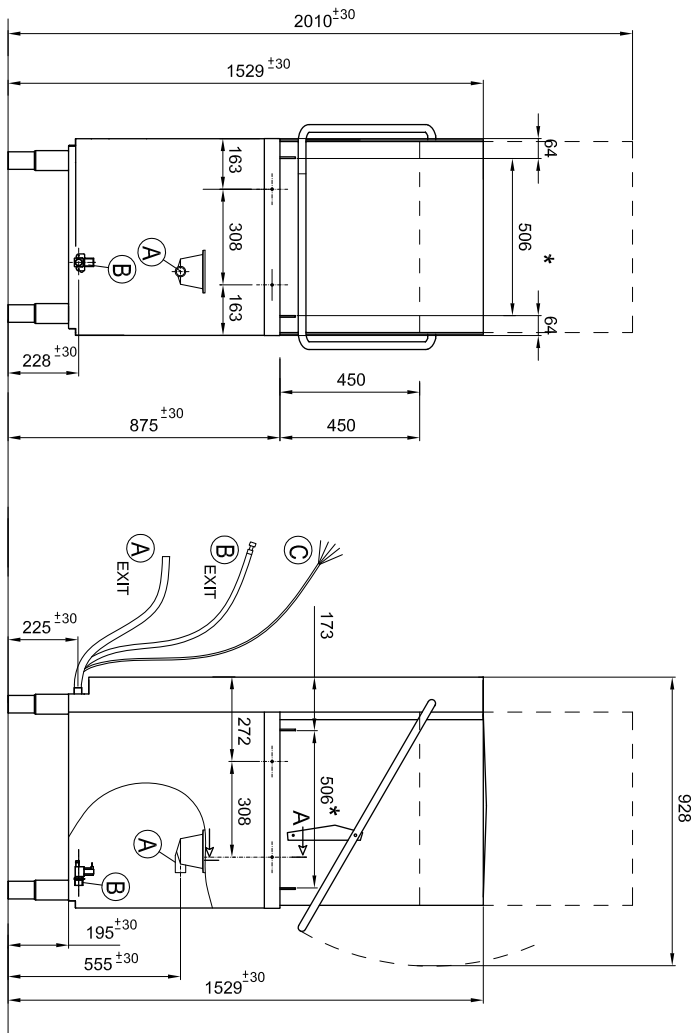
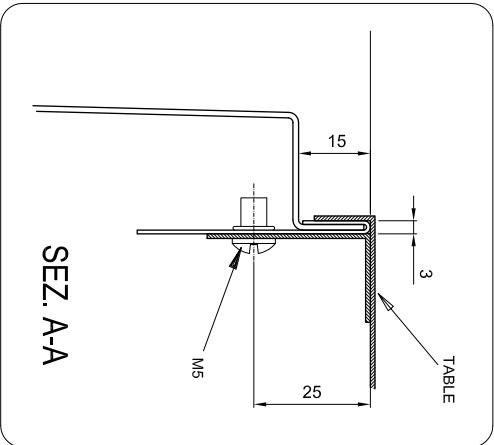
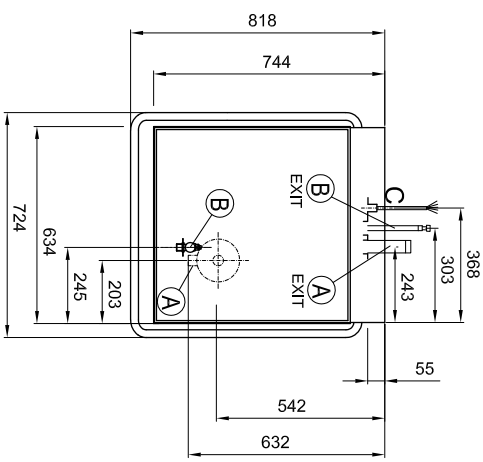

\* LUCE UTILE PER CESTELLO  
 USEFUL SPACE FOR BASKET  
 LUMIERE UTILE POUR PANIER  
 NUTZBARE OFFNUNG FÜR KORBE  
 ABERTURA UTIL PARA CESTO

Installation layout

Hood type

NH50

00

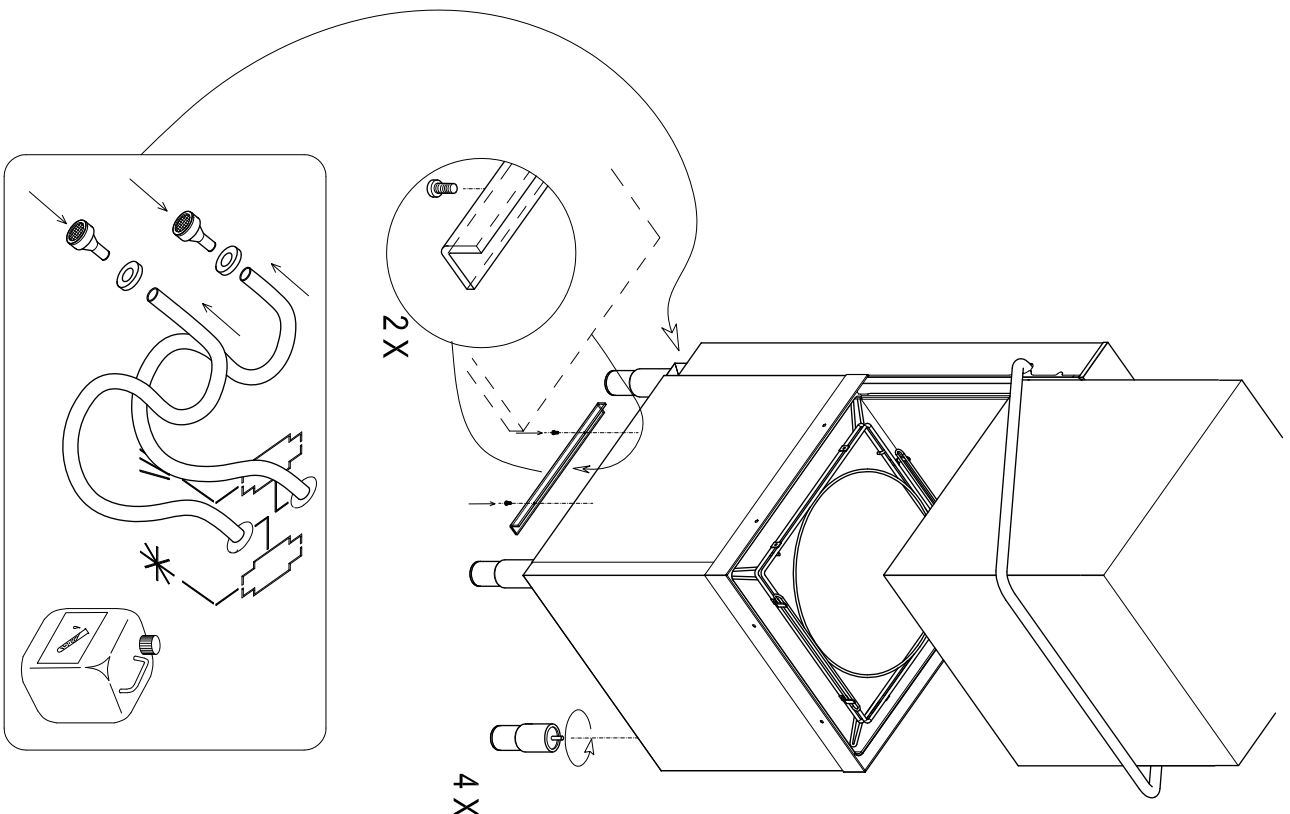

Designed by:

M.P.UCCI

Date:

15.07.2014

Denomination:

Code:

Rev.:



The machine is equipped with specific outputs for rinse aid and detergent dosing devices, connect the dosing devices as shown in the wiring diagram to ensure the correct operation of the machine.

The machine cannot be fitted with multi-voltage dosing devices and/or dosing devices with absorption higher than 5A per output.

If you wish to use this type of dosing device, it must be connected to an external 16A relay.

Malfunctions and faults caused by connections to the dosing devices that do not comply with the machine wiring diagram will annul the warranty.

---

Installation of dosing devices other than those supplied by us must be checked by an installation technician.



La macchina è predisposta di uscite specifiche per i dosatori del brillantante e del detergente, collegare i dosatori come indicato dallo schema elettrico per garantire il buon funzionamento della macchina.

La macchina non supporta dosatori multi-tensione e/o con assorbimento superiore a 5A per uscita. Nel caso si voglia adottare questo tipo di dosatore, dovrà essere collegato ad un relè esterno da 16A.

I malfunzionamenti o guasti derivati dal collegamento di dosatori non conforme allo schema elettrico della macchina, comporterà la decadenza della garanzia.

---

L'installazione di dosatori diversi da quelli da noi forniti deve essere verificata dal tecnico installatore.



Am Gerät ist jeweils ein spezifischer Ausgang für den Klarspülmitteldosierer und den Spülmitteldosierer vorhanden. Schließen Sie die Dosierer nach den Vorgaben des Stromlaufplans an, um die einwandfreie Funktion des Gerätes sicherzustellen.

Die Maschine ist nicht für Multispannungs-Dosierer und/oder eine Stromaufnahme von über 5 A je Ausgang ausgelegt.

Falls ein derartiger Dosierer verwendet werden soll, muss er an ein externes 16-A-Relais angeschlossen werden.

Ein von den Vorgaben des Stromlaufplans abweichender Anschluss der Dosierer hat den Verlust der Garantie zur Folge, für eventuelle Betriebsstörungen oder Schäden wird keine Haftung übernommen.

---

Die Installation von Dosierern anderer Hersteller muss von einem Installationstechniker überprüft werden.



La machine est prévue pour disposer de sorties spécifiques pour les doseurs du liquide de rinçage et du détergent liquide ; raccorder les doseurs comme représenté dans le schéma électrique pour garantir le bon fonctionnement de la machine.

La machine ne s'accommode pas de doseurs multitension et/ou dont la consommation est supérieure à 5 A par sortie.

Pour pouvoir adapter ce type de doseur sur la machine, celui-ci devra être raccordé à un relais extérieur de 16A.

Les anomalies de fonctionnement ou toute autre panne provenant d'un faux branchement (non représenté dans le schéma électrique ou qui diverge du schéma électrique de la machine) entraînera l'annulation de plein droit de la garantie.

---

L'installation de doseurs autres que ceux fournis par nous doit être vérifiée par l'installateur.



La máquina está provista de salidas específicas para los dosificadores del abrillantador y del detergente: para asegurar el correcto funcionamiento de la máquina, conecte los dosificadores como se indica en el esquema eléctrico.

La máquina no funciona con dosificadores multi-tensión y/o con absorción superior a 5 A por salida. Si se desea utilizar este tipo de dosificador, deberá conectarse a un relé externo de 16 A.

Los fallos o averías causados por la conexión de dosificadores no conforme al esquema eléctrico de la máquina conlleva la anulación de la garantía.

La instalación de dosificadores distintos a los que suministramos debe ser comprobada por el técnico