



MAGISTRA PLUS 700 - FRYERS

MFRE77T



2 BOWLS, ELECTRIC TOP

TECHNICAL DATA:

External dimensions - WxDxH (cm)	70x71,4x25
Tank capacity (lt-GN)	12+12
Total power (kW)	9+9= 18

ADDITIONAL TECHNICAL DATA:

Tank dimensions - WxDxH (cm)	28x34x20
Supply (N)	400V 3N 50Hz
Weight (kg)	53
Volume (m3)	0,32

The 18/10 AISI 304 stainless steel tanks are moulded and continuous-welded with rounded corners for easy cleaning and sanitation. All models have safety thermostat and thermostatic temperature control to keep the oil temperature within safety parameters.

A large front drainer for greater ease of use and cleaning. The used oil outlet system is simple and safe with an oil collection tank with stainless steel filter. 1 mm worktop in AISI 18/10 stainless steel. Excellent alignment with joints.

Gas versions: high output stainless steel burner with horizontal flame, safety valve and thermocouple, automatic ignition with pilot flame and piezoelectric device.

Electric versions: armoured stainless steel electric heating elements inside the tank, easily tilted for complete cleaning.

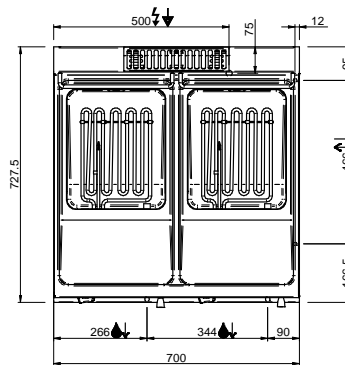
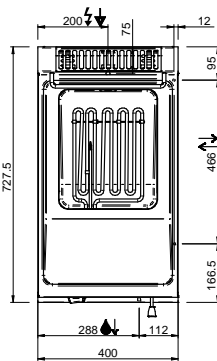
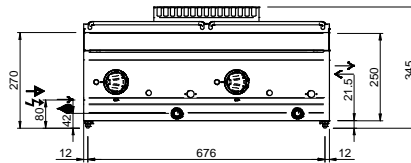
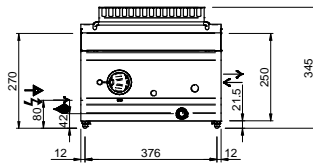

LEGENDA SIMBOLI / LEGEND



INGRESSO GAS / GAS INLET
(EN 10226-1) Ø M 1/2"



ALIMENTAZIONE ELETTRICA /
POWER SUPPLY



INGRESSO ACQUA /
WATER INLET Ø M 1/2"



SCARICO ACQUA / OLII
WATER / OILS DRAIN



ATTACCO EQUIPOTENZIALE /
EQUIPOTENTIAL



REGOLAZIONE PIEDINI /
FEET ADJUSTMENT (h 0/+50)
/ TOP VERSION (h 0/+5)