



DOMINA PRO 700 - CHIP SCUTTLE

SP74T

ELECTRIC CHIP SCUTTLE, TOP



TECHNICAL DATA:

External dimensions - WxDxH (cm)	40x73x50
Total power (kW)	1,35
IPX5	●

ADDITIONAL TECHNICAL DATA:

Tank dimensions - WxDxH (cm)	31x51x16
Supply (N)	230V 1N 50/60Hz
Weight (kg)	23,5
Volume (m3)	0,2

The GN 1/1 AISI 304 stainless steel tank is moulded and continuous-welded.

Equipped with double perforated bottom inclined to remove excess frying oil. Electric heating with armoured stainless steel elements, set on the external bottom of the tanks and infrared heating element on top.

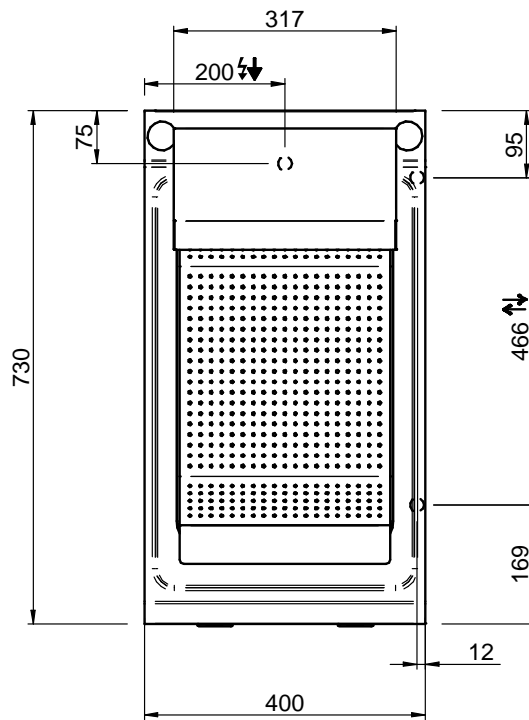
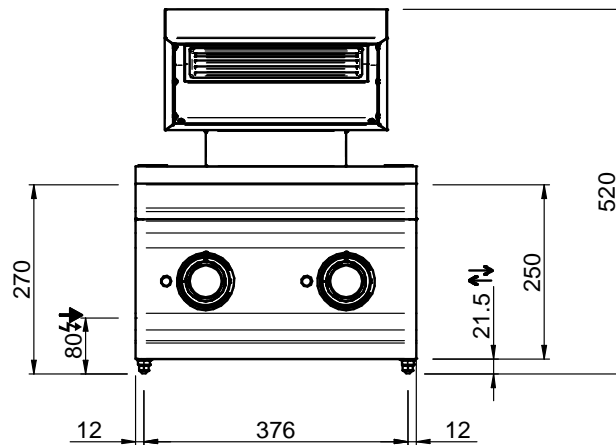

LEGENDA SIMBOLI / LEGEND



INGRESSO GAS / GAS INLET
(EN 10226-1) Ø M 1/2"



INGRESSO ACQUA /
WATER INLET Ø M 1/2"



ATTACCO EQUIPOTENZIALE /
EQUIPOTENTIAL



SCARICO ACQUA / WATER OUTLET



SCARICO ACQUA / WATER OUTLET



REGOLAZIONE PRESSIONE / PRESSURE REGULATION